

WIRING DIAGRAMS



BUSES 8000-8149

I N D E X

FLXIBLE 8000-8149

<u>Circuit</u>	<u>Drawing No.</u>	<u>Page</u>
Buzzer and Horn	SK.E-112956	1
Charging Circuit	SK.E-112856	2
Emergency Lights	SK.E-12066	7A
Door Control	SK.E-120356	3
Heat and Vent. Vapor Heating	SK.E-113056	4
Heat and Vent. Minneapolis-Honeywell	SK.E-113056-A	5
Horn and Buzzer	SK.E-112956	1
Ignition, 8050-8149 without Fast Idle	SK.E-112756	6
Ignition, 8000-8049 with Fast Idle	SK.E-032064	6AB
Light Circuits--Revised, 1-20-66	SK.E-120456	7
Shift Circuit, Revised 12-5-63	SK.E120563	8
Shift Circuit, Revised 9-17-63	SK.E120656	8
Starting	SK.E112656	9
Vent and Heat, Vapor Heating	SK.E-113056	4
Vent and Heat, Minneapolis-Honeywell	SK.E-113056-A	5
Lamp Data		10

GBU:cg

Revised 4-13-64, 2-15-66

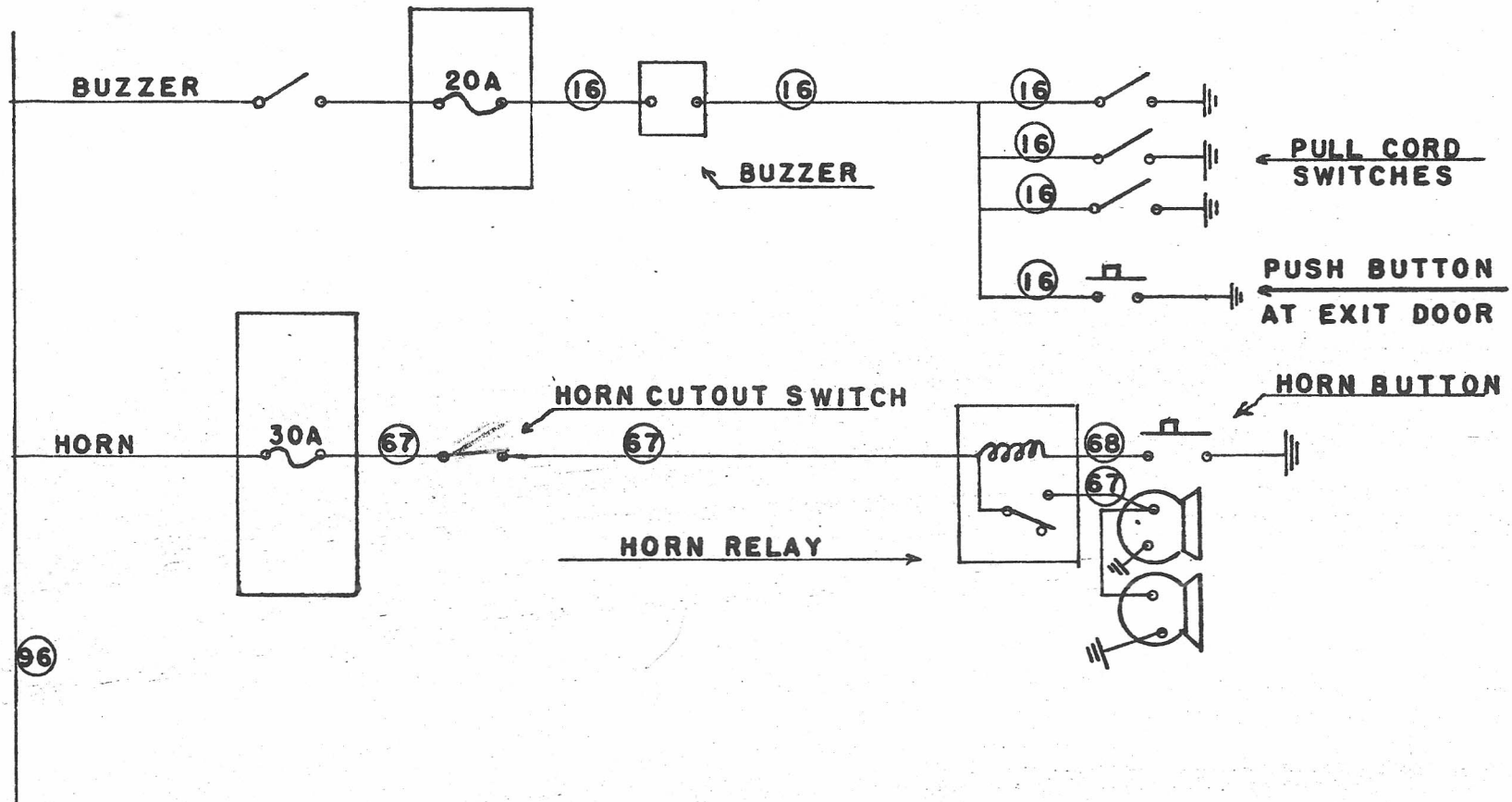

**BUZZER & HORN CIRCUITS
8000-8149**

CHICAGO TRANSIT AUTHORITY
GENERAL SUPERINTENDENT OF ENGINEERING
EQUIPMENT ENGINEER'S OFFICE

SK-E-112956

GENERATOR
INDICATOR
LIGHT ON DASH

TELLTALE LIGHT
RECTIFIER

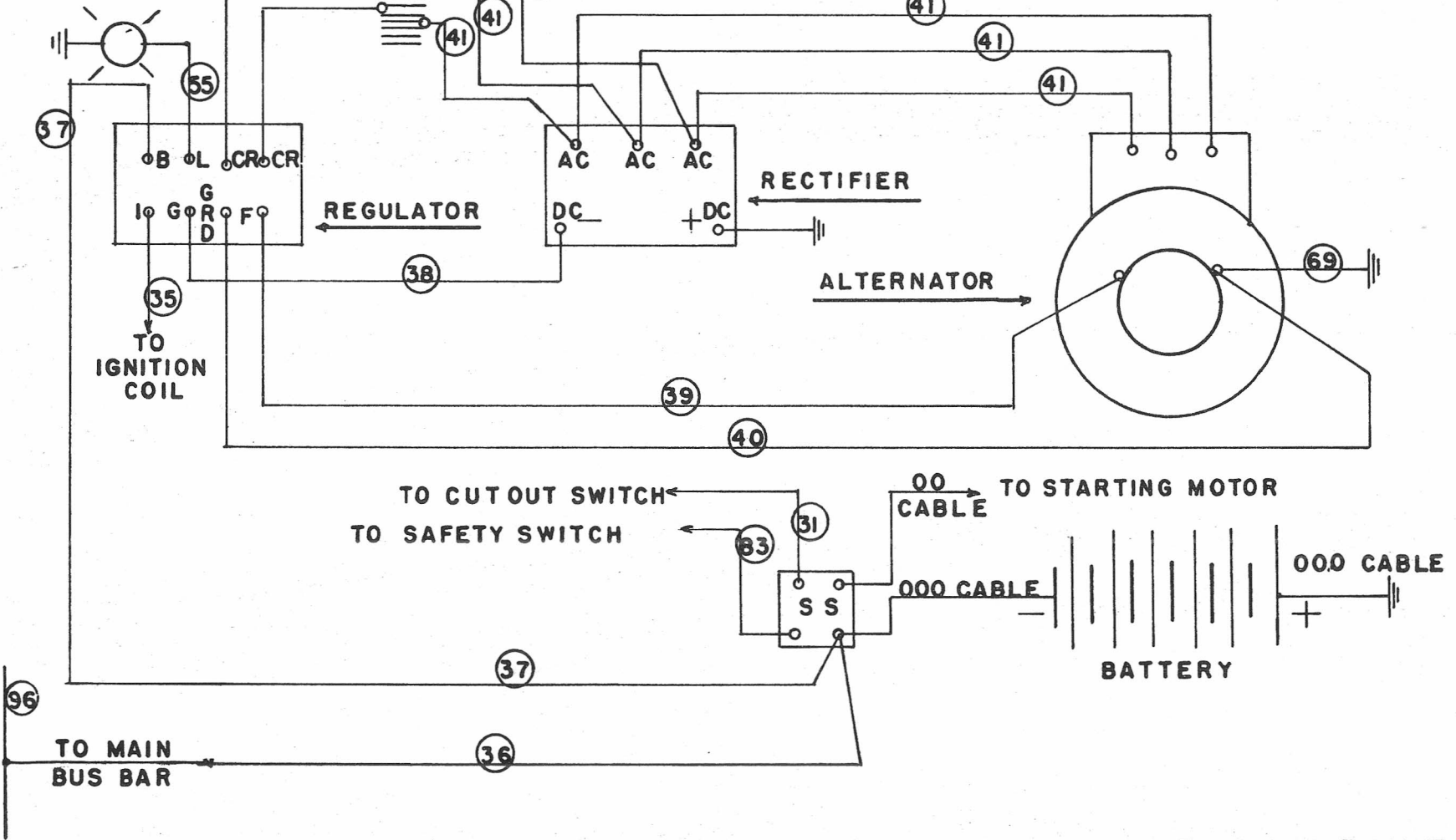

SS - STARTER SOLENOID

CHARGING CIRCUIT
8000-8148

CHICAGO TRANSIT AUTHORITY
GENERAL SUPERINTENDENT OF ENGINEERING
EQUIPMENT ENGINEER'S OFFICE

SK-E-112856

GENERATOR
INDICATOR LIGHT
ON DASH

TELLTALE LIGHT
RECTIFIER

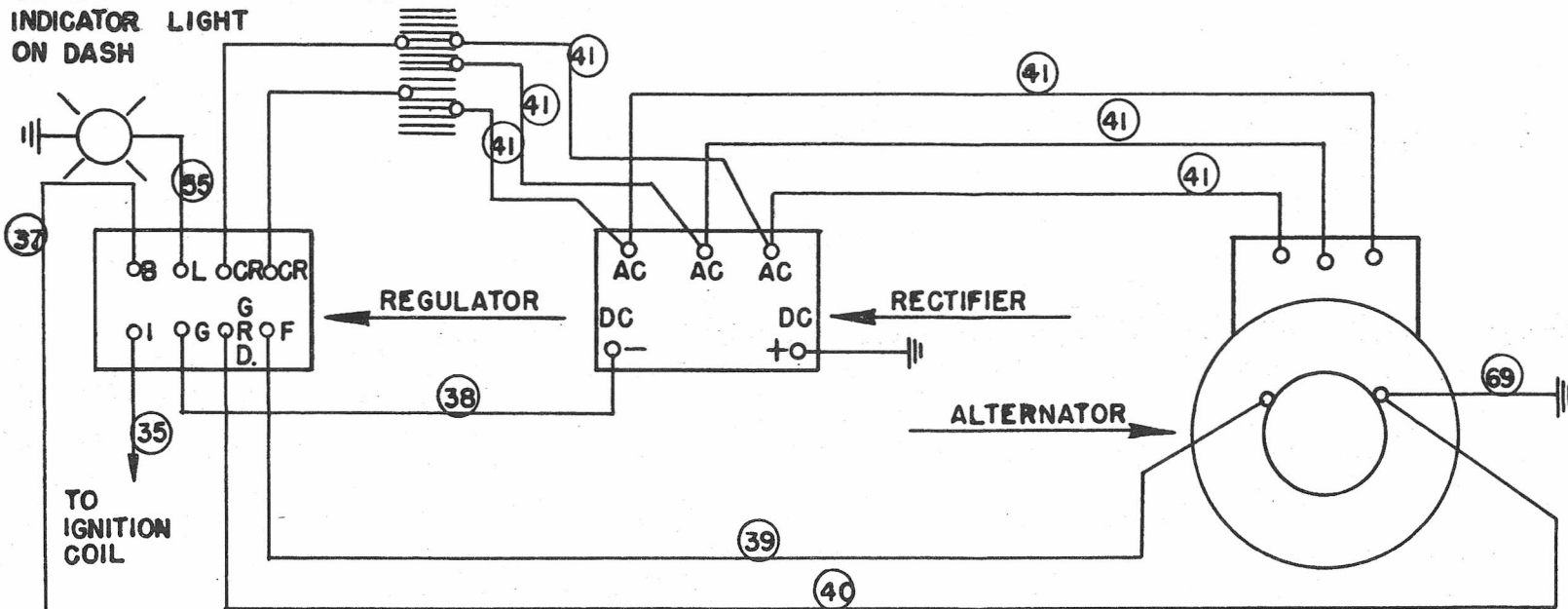

TO
IGNITION
COIL

BATTERY NO. ONE

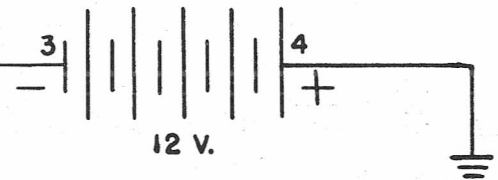

TO SHIFT
TOWER

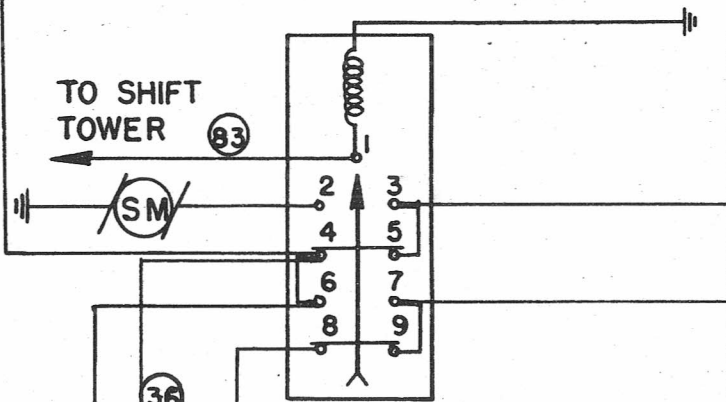

BATTERY NO. TWO

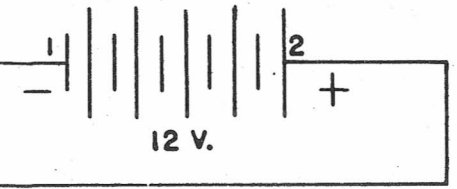

TO MAIN
BUS BAR

CHARGING CIRCUIT
8149

CHICAGO TRANSIT AUTHORITY
GENERAL SUPERINTENDENT OF ENGINEERING
EQUIPMENT ENGINEER'S OFFICE

SK-E-12960

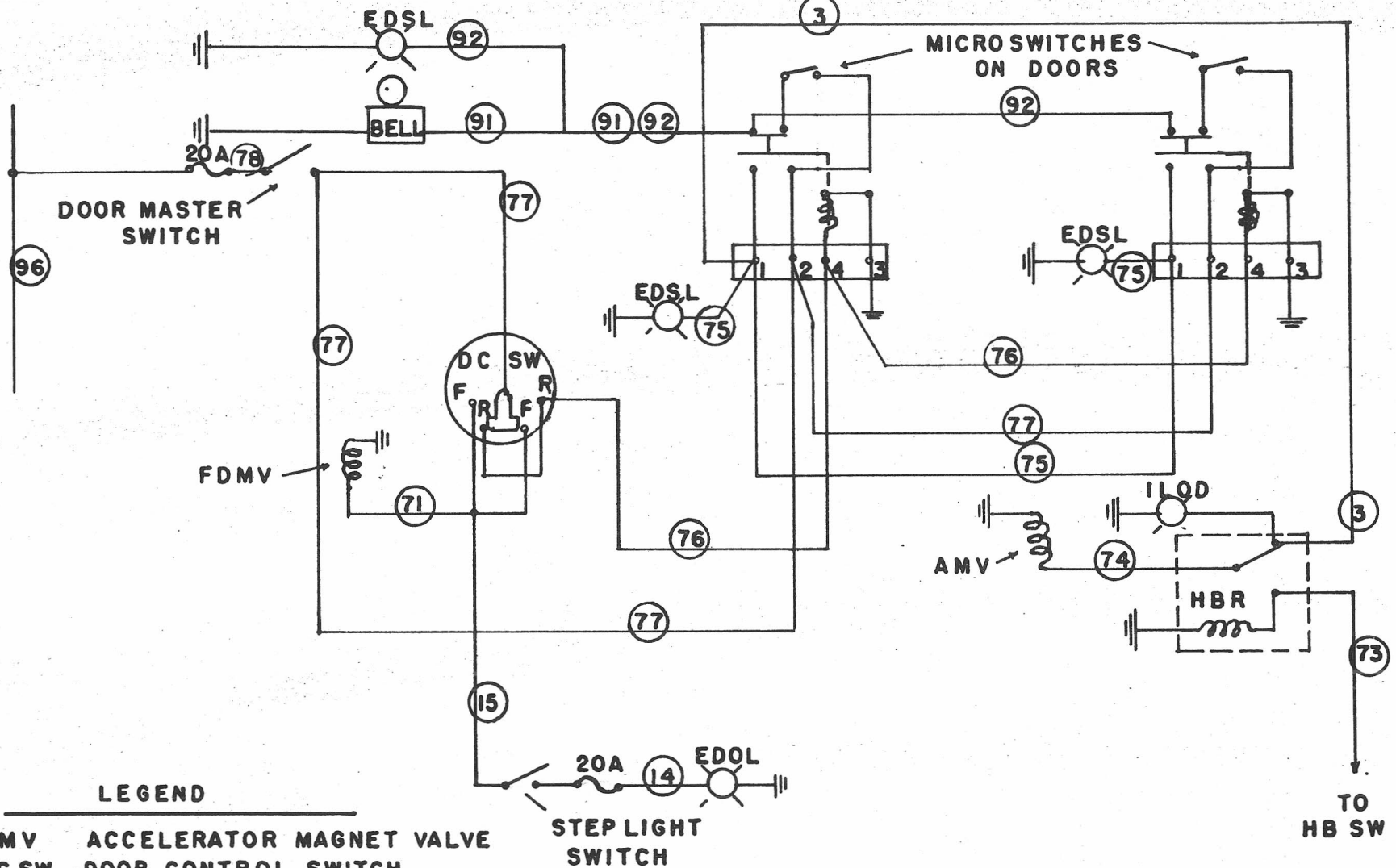

LEGEND

- AMV ACCELERATOR MAGNET VALVE
- DC SW DOOR CONTROL SWITCH
- EDOL ENTRANCE DOOR OVERHEAD LIGHT
- EDSL EXIT DOOR SIGNAL LIGHT
- FDMV FRONT DOOR MAGNET VALVE
- ILOD INDICATOR LIGHT ON DASH
- HBR HANDBRAKE RELAY
- HB SW HANDBRAKE SWITCH

**DOOR CONTROLS
8000-8149
CONSOLIDATED**

**CHICAGO TRANSIT AUTHORITY
GENERAL SUPERINTENDENT OF ENGINEERING
EQUIPMENT ENGINEER'S OFFICE**

SK-E-120356

VAPOR HEATING

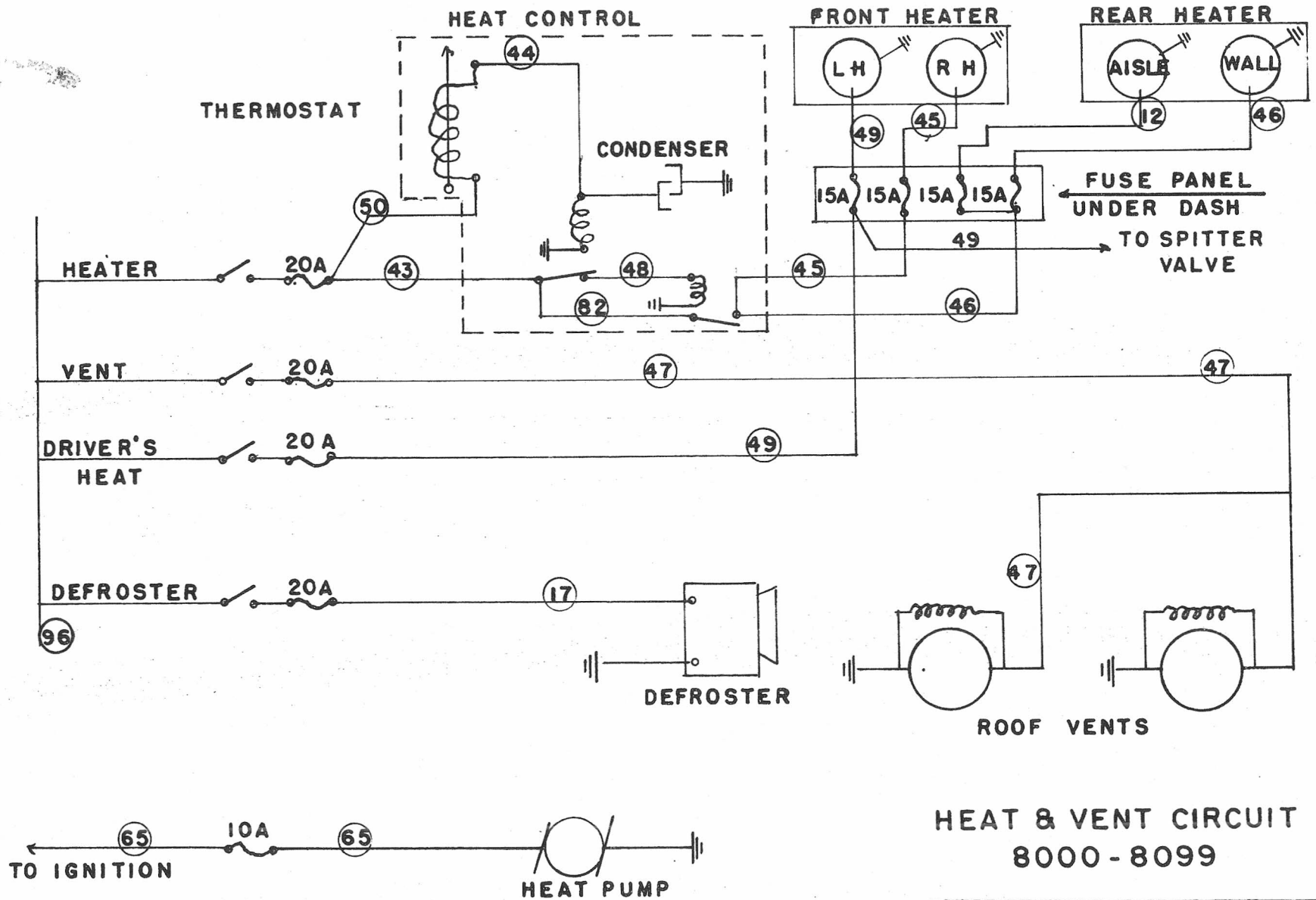

HEAT & VENT CIRCUIT
8000 - 8099

CHICAGO TRANSIT AUTHORITY
GENERAL SUPERINTENDENT OF ENGINEERING
EQUIPMENT ENGINEER'S OFFICE

SK-E-113056

MINNEAPOLIS HONEYWELL
HEAT CONTROL

FRONT HEATER

REAR HEATER

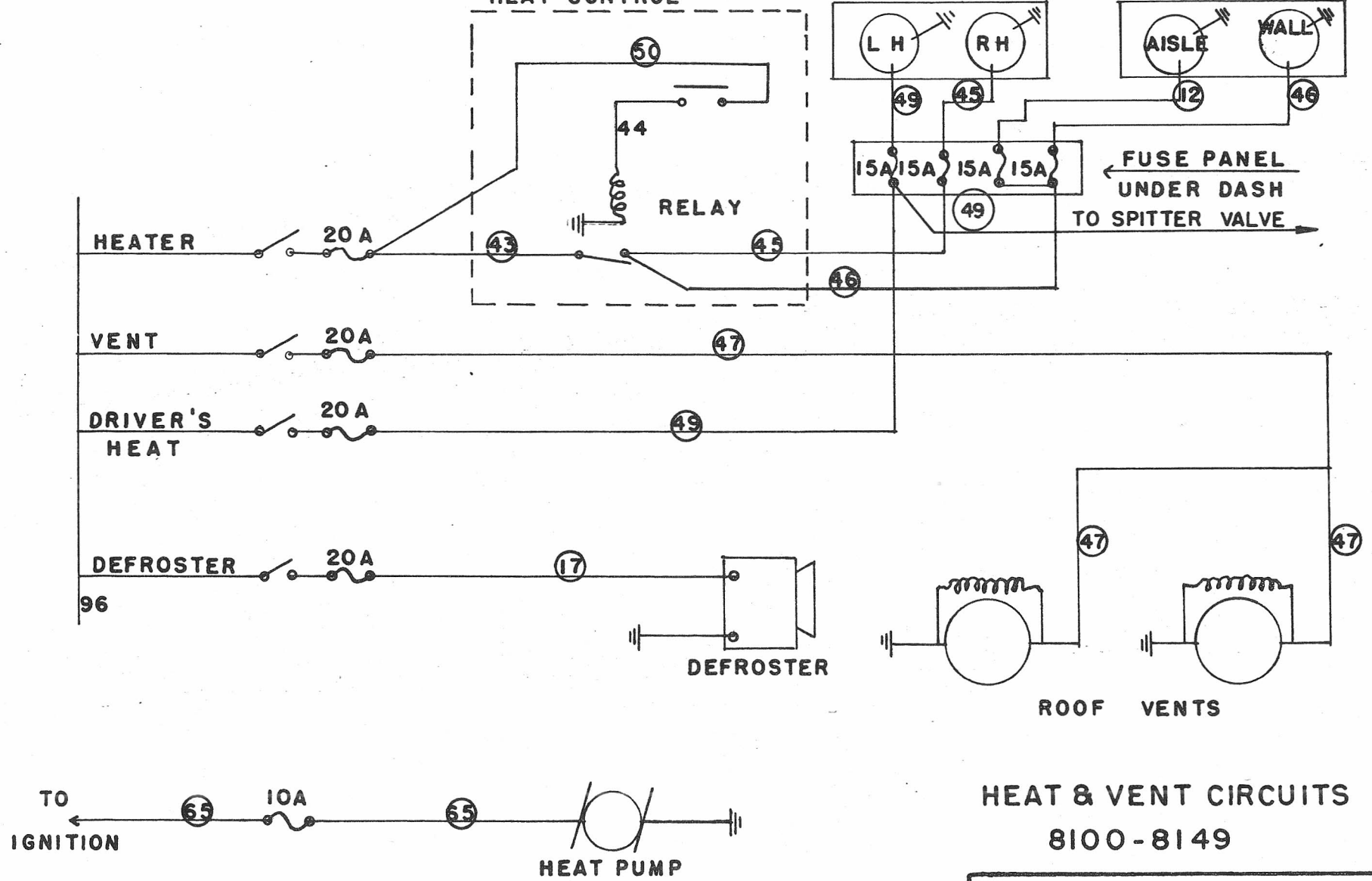

HEAT & VENT CIRCUITS

8100-8149

CHICAGO TRANSIT AUTHORITY
GENERAL SUPERINTENDENT OF ENGINEERING
EQUIPMENT ENGINEER'S OFFICE

REVISED 1-29-60

SK-E-113056 A

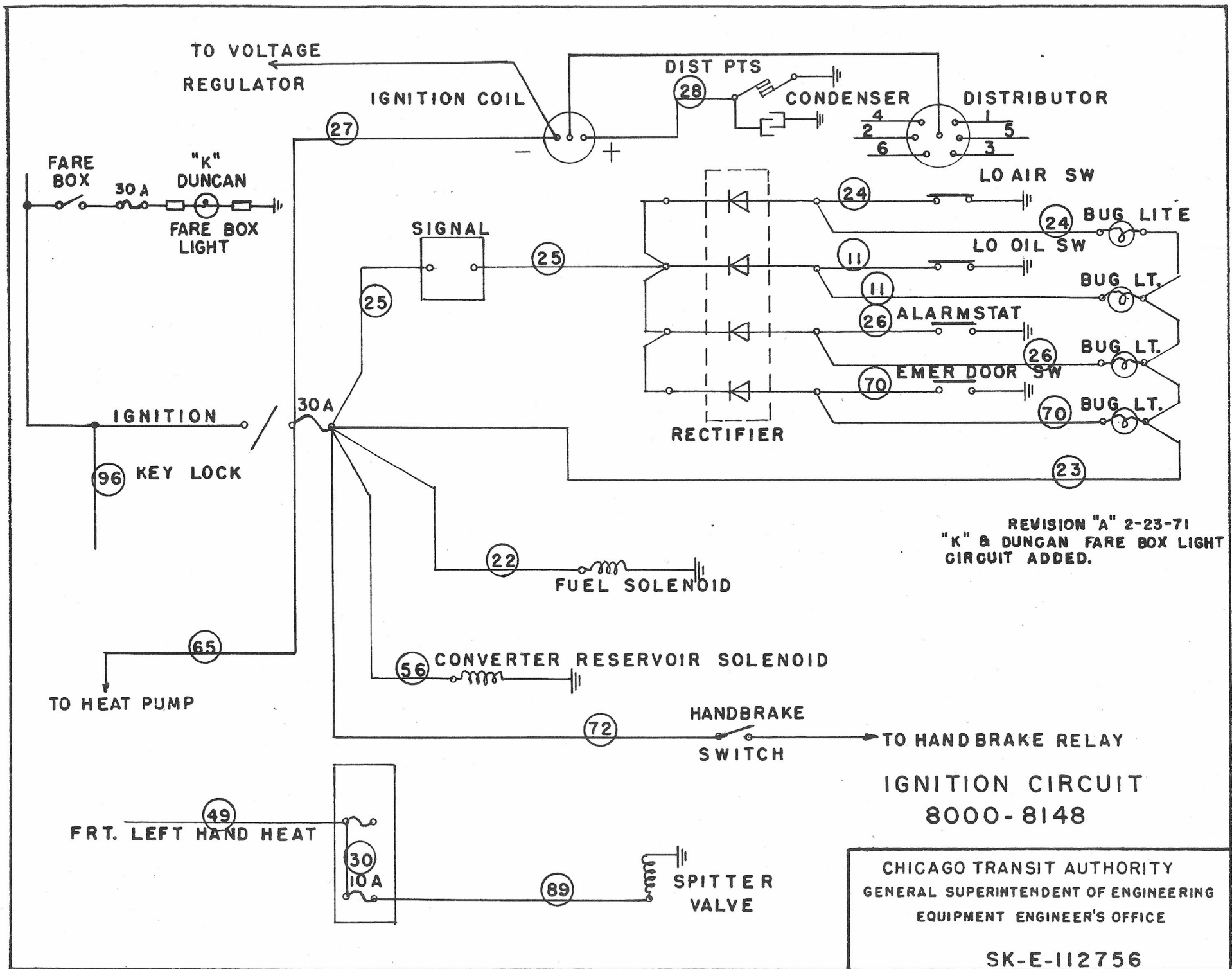

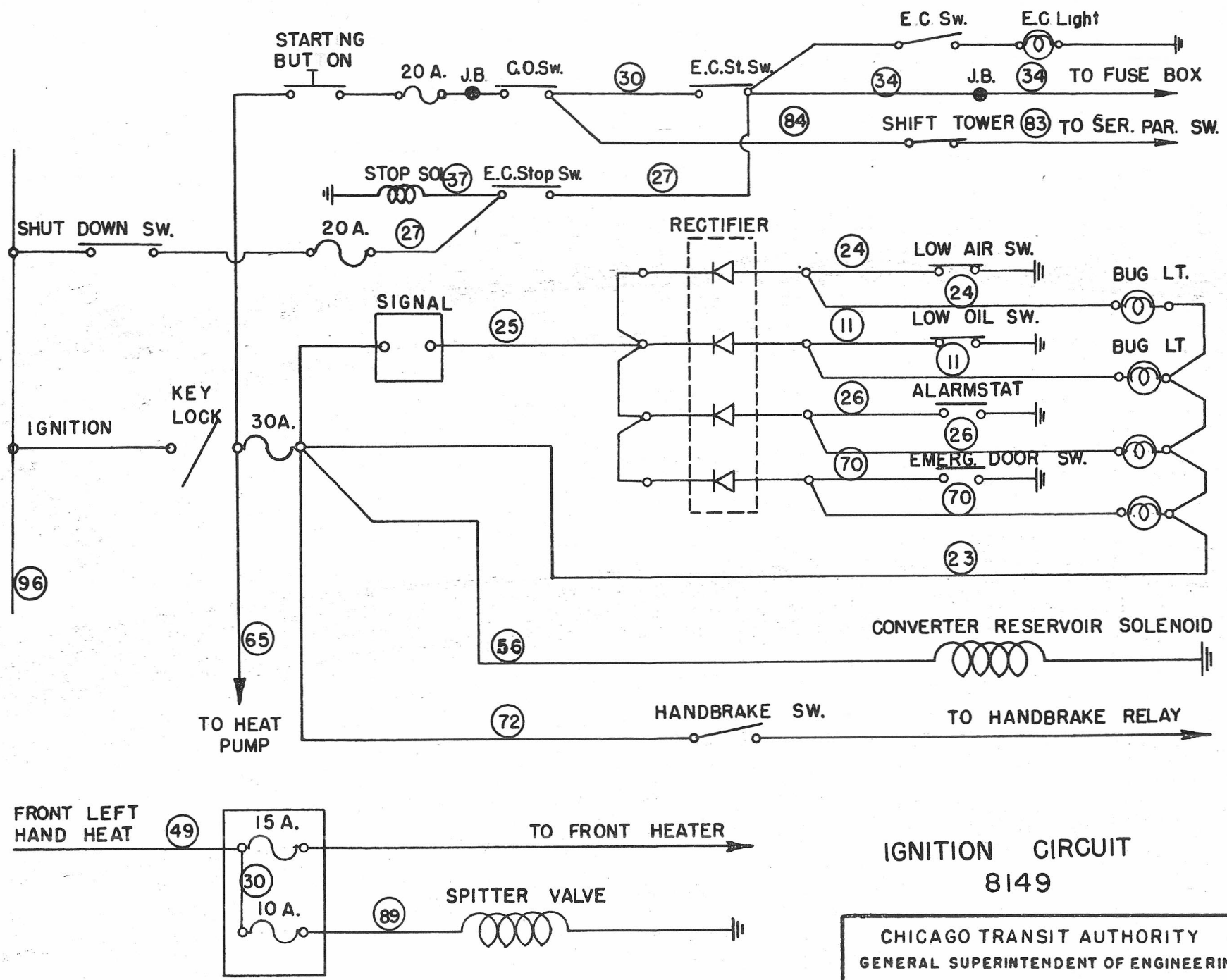

IGNITION CIRCUIT
8149

CHICAGO TRANSIT AUTHORITY
GENERAL SUPERINTENDENT OF ENGINEERING
EQUIPMENT ENGINEER'S OFFICE
SK - E - 20160

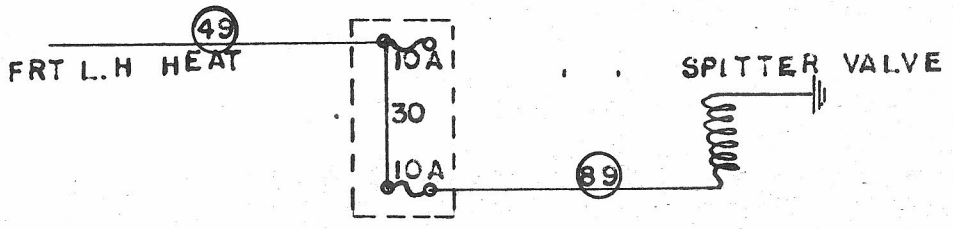
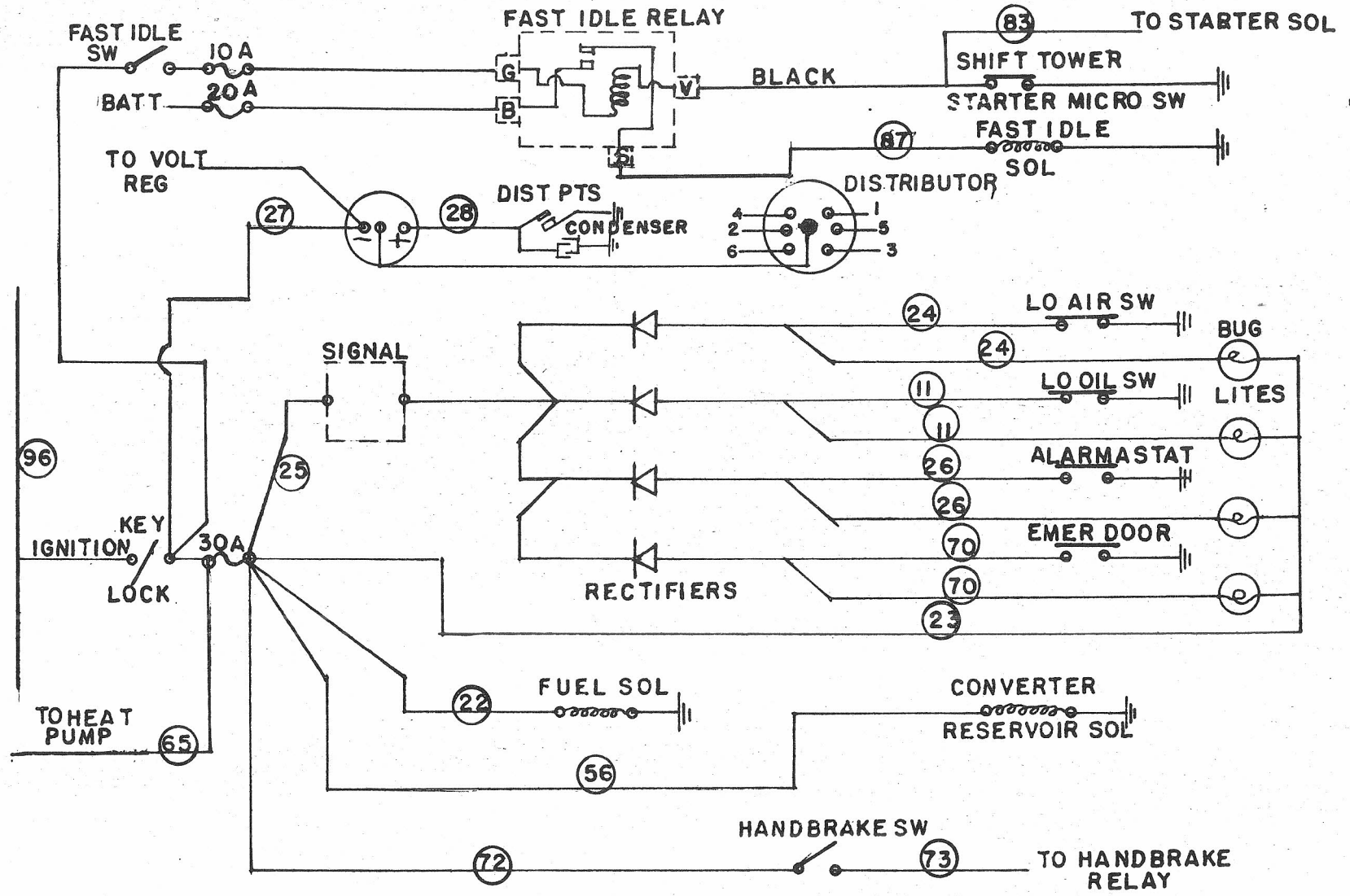

**IGNITION CIRCUIT
8000-8049**

**CHICAGO TRANSIT AUTHORITY
GENERAL SUPERINTENDENT OF ENGINEERING
EQUIPMENT ENGINEER'S OFFICE**

SK-E-032064

Revised 7-1-64

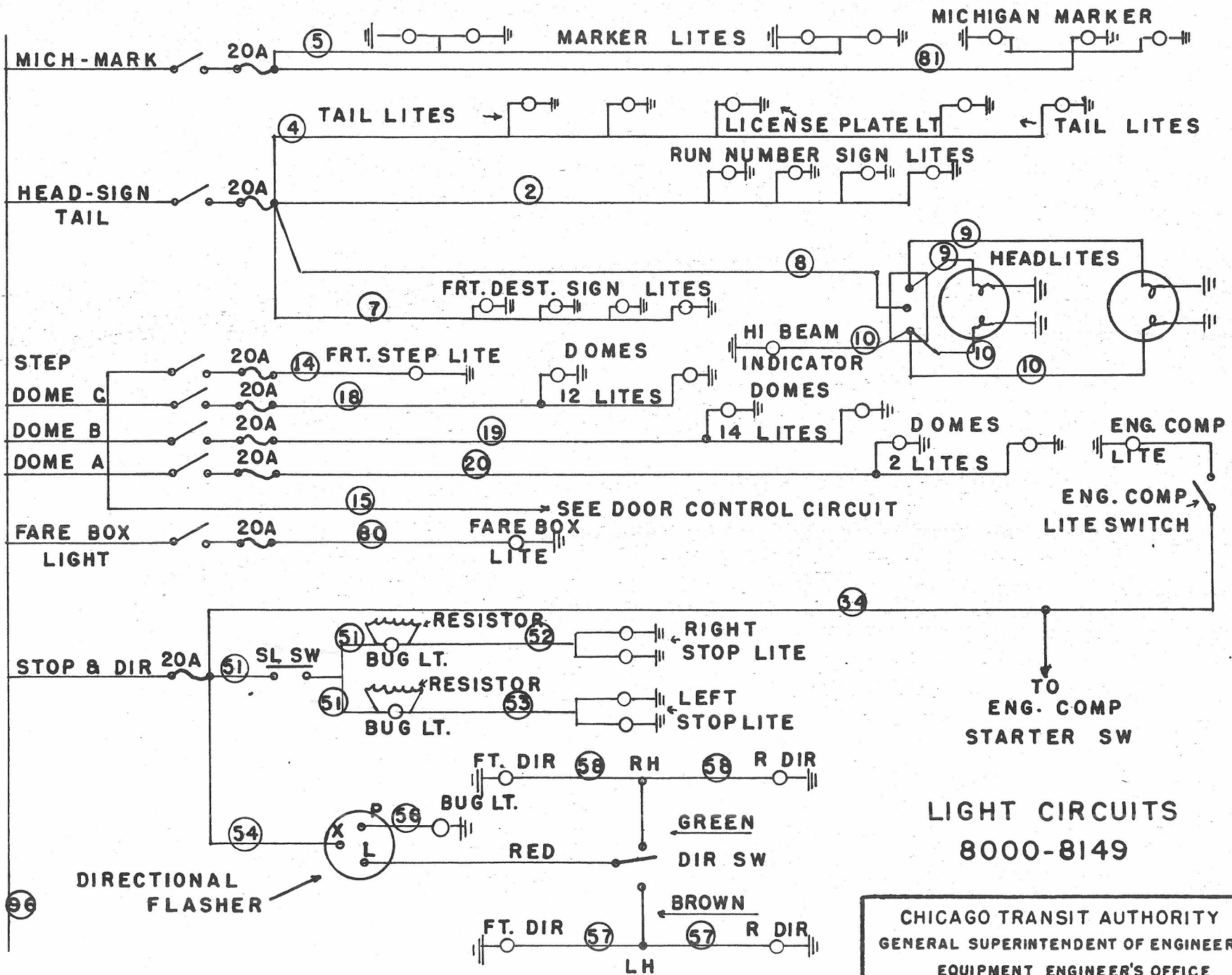

**LIGHT CIRCUITS
8000-8149**

CHICAGO TRANSIT AUTHORITY
GENERAL SUPERINTENDENT OF ENGINEERING
EQUIPMENT ENGINEER'S OFFICE

SEE PAGE 7A FOR EMERGENCY FLASHER LIGHTS REVISED 1-20-66

SK-E-120456

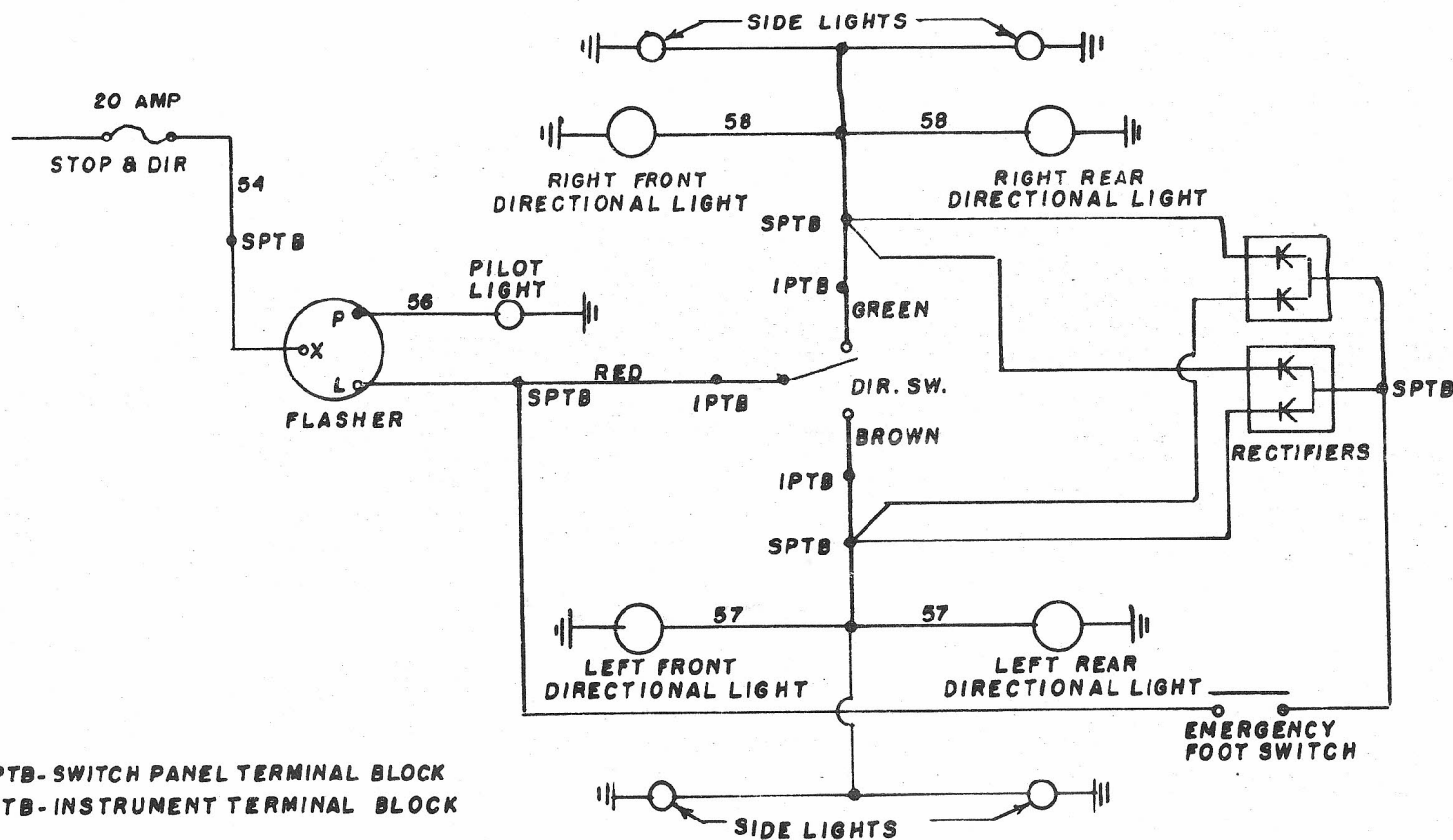

AS PER BULLETIN NO. C-7-036

SERIES 8000-8148

CHICAGO TRANSIT AUTHORITY
EQUIPMENT RESEARCH & DEVELOPMENT
OFFICE OF CHIEF EQUIPMENT ENGINEER
DATE 1-20-66

E-12066

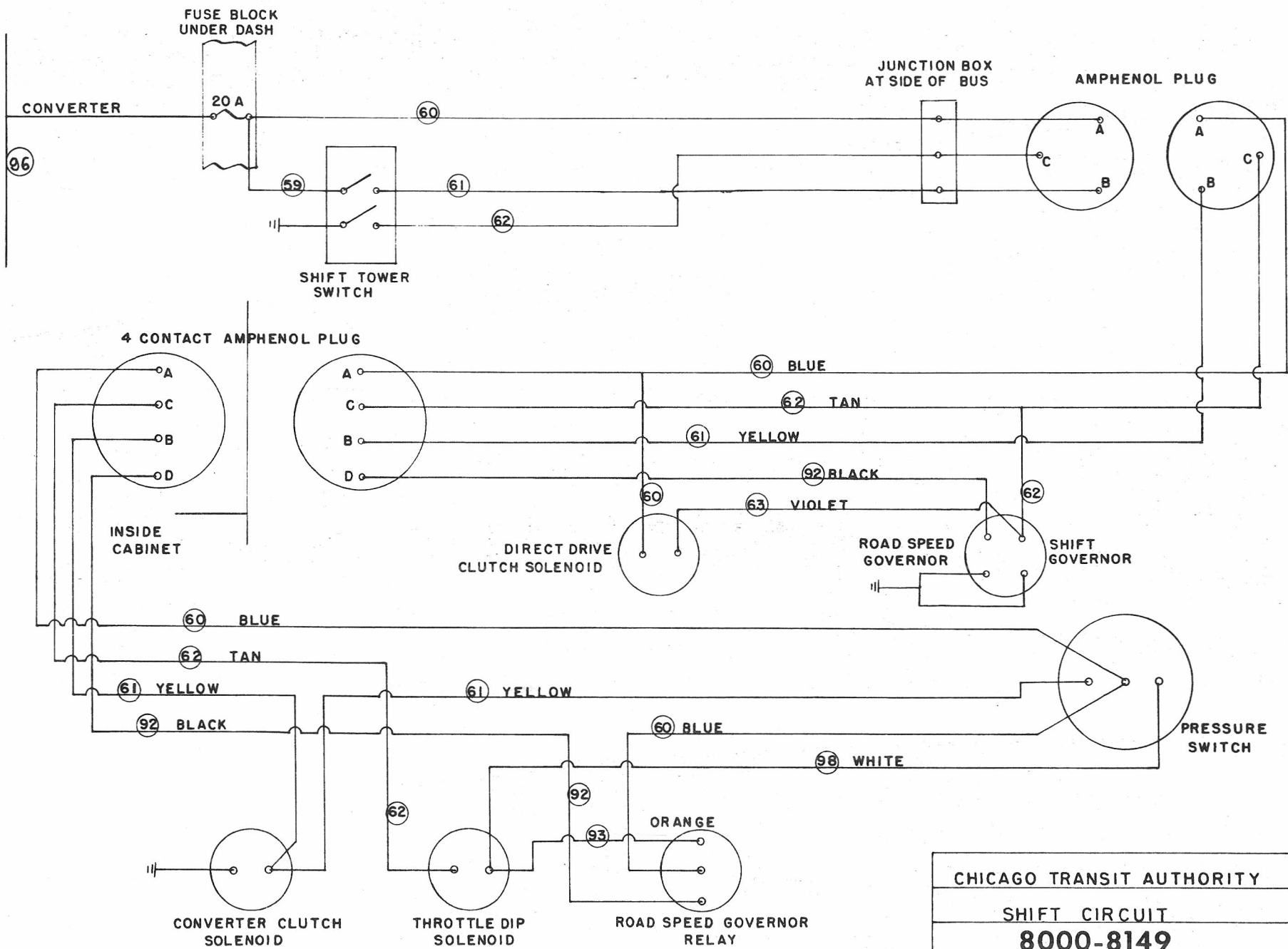

REVISED 11-8-63

RETAIN PAGE 8 (THROTTLE DIP CIRCUIT-SK-E-82558-6)
UNTIL CAMPAIGN C-17-019 IS COMPLETED.

REVISED 12-5-63

REVISED 11-8-63

REVISED 9-17-63

CHICAGO TRANSIT AUTHORITY

SHIFT CIRCUIT

8000-8149

GENERAL SUPERINTENDENT OF ENGINEERING

OFFICE OF ENGINEER OF EQUIPMENT

SK-E-120563

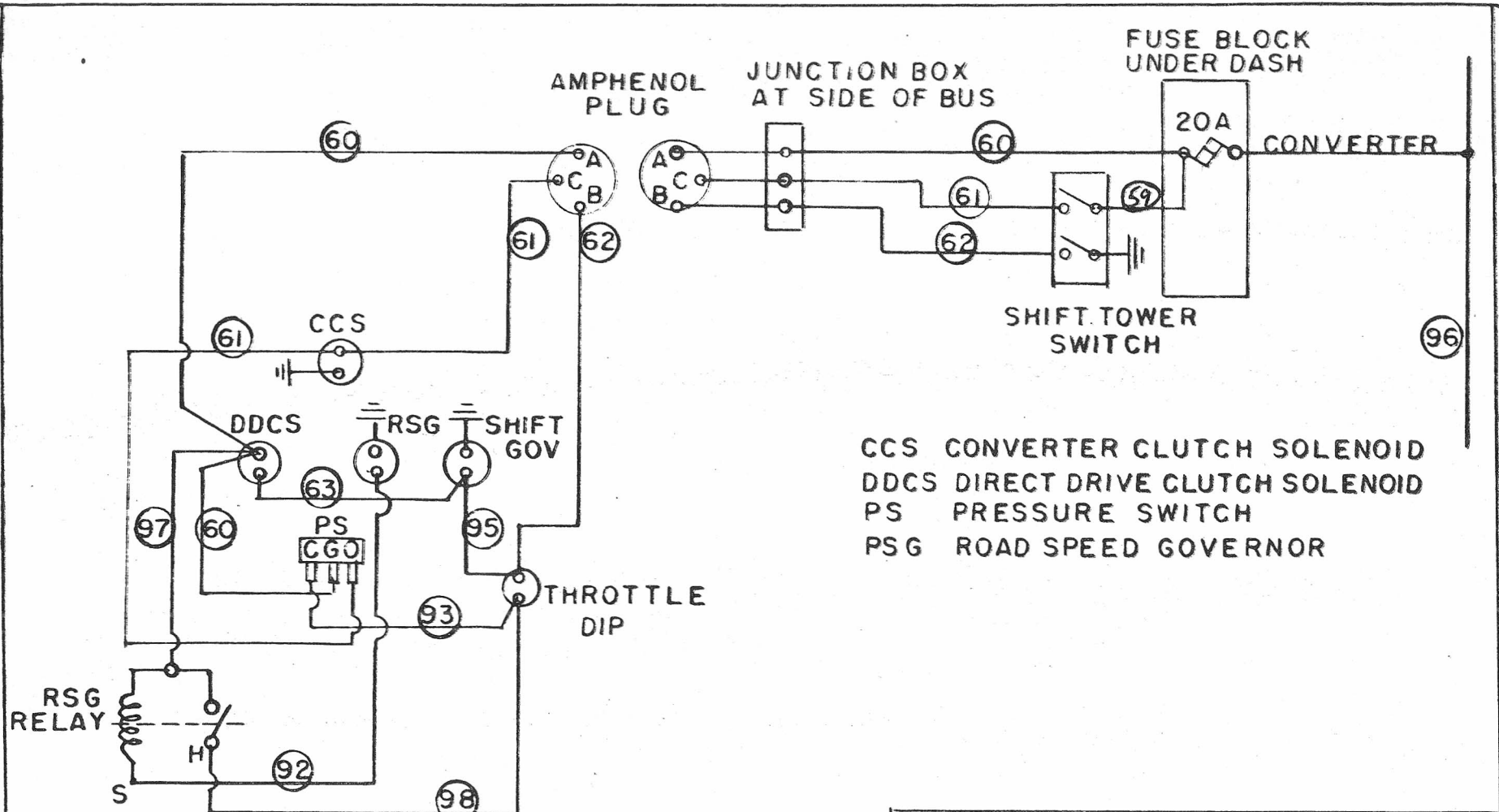

CCS CONVERTER CLUTCH SOLENOID
 DDCS DIRECT DRIVE CLUTCH SOLENOID
 PS PRESSURE SWITCH
 PSG ROAD SPEED GOVERNOR

SHIF T CIRCUIT
 8000-8149

CHICAGO TRANSIT AUTHORITY
 OPERATING MANAGER
 OFFICE OF ENGINEER OF EQUIPMENT

REVISED AS PER BULLETIN NO. C-17-010

1-12-65

GBU

SK-E-120656

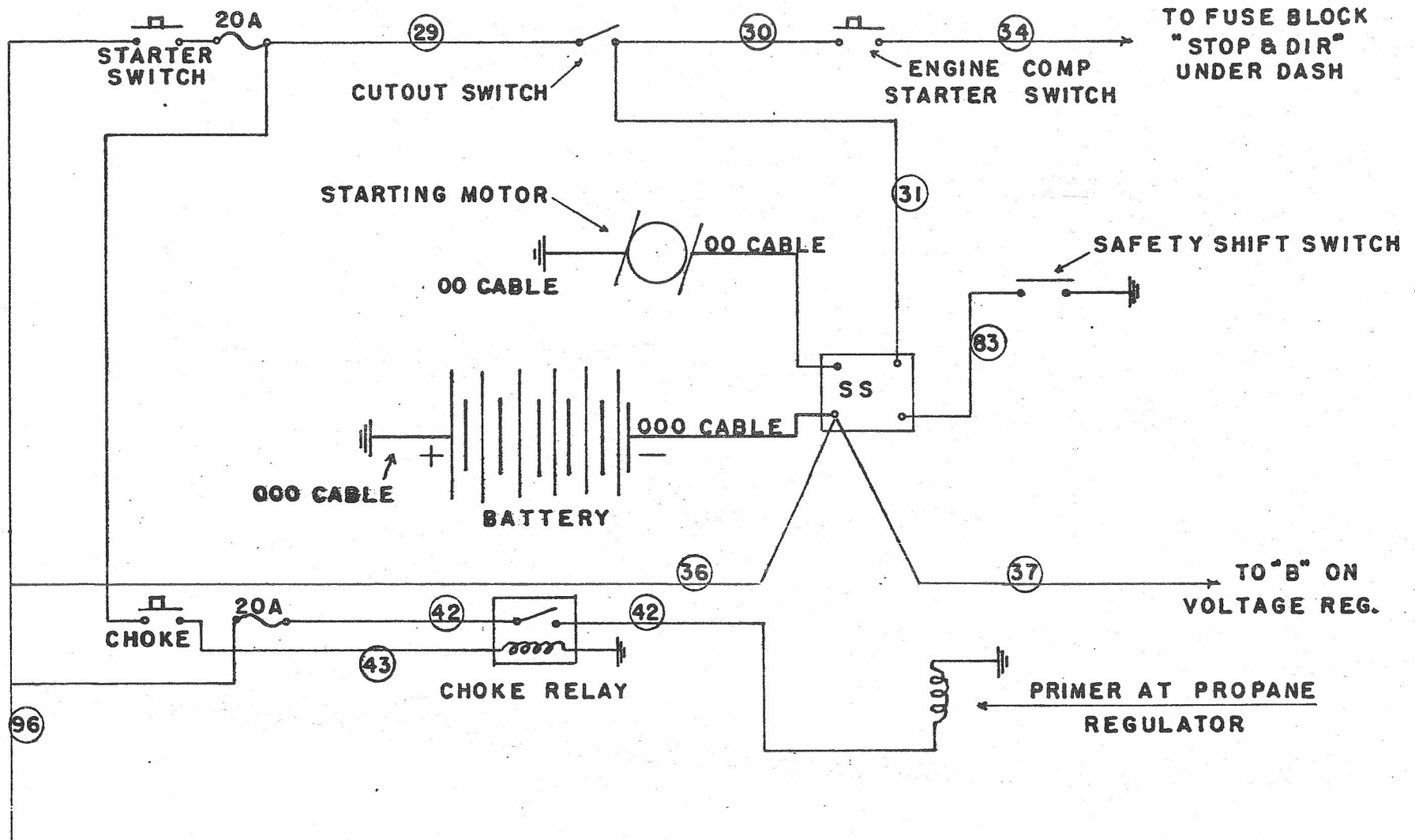

SS STARTER SOLENOID

**STARTING CIRCUIT
8000-8149**

CHICAGO TRANSIT AUTHORITY
 GENERAL SUPERINTENDENT OF ENGINEERING
 EQUIPMENT ENGINEER'S OFFICE
 SK-E-112656

LAMP DATA	
LOCATION	LAMP NO.
DESTINATION SIGN	94
DIRECTIONAL SIGNAL	1141
DOMES	93L
ENGINE COMPARTMENT	89
EXIT DOOR SIGNAL	89
FARE BOX	94 IF
FRONT STEP	94 IF
INDICATOR LIGHTS	57
HEADLIGHTS	4430 OR 5440
LICENSE PLATE	89
MARKER-FRONT	68
MARKER-REAR	67
MICHIGAN MARKER	67
RUN NUMBER SIGN	67
STOPLIGHT	81
STOPLIGHT INDICATOR	55
TAIL LIGHT	89
WARNING LIGHT-EXIT DOOR	67

8000 - 8149

CHICAGO TRANSIT AUTHORITY
 GENERAL SUPERINTENDENT OF ENGINEERING
 EQUIPMENT ENGINEER'S OFFICE

SK-E-122757

